

miriac™ VME200

VMEbus CPU board

Product Overview

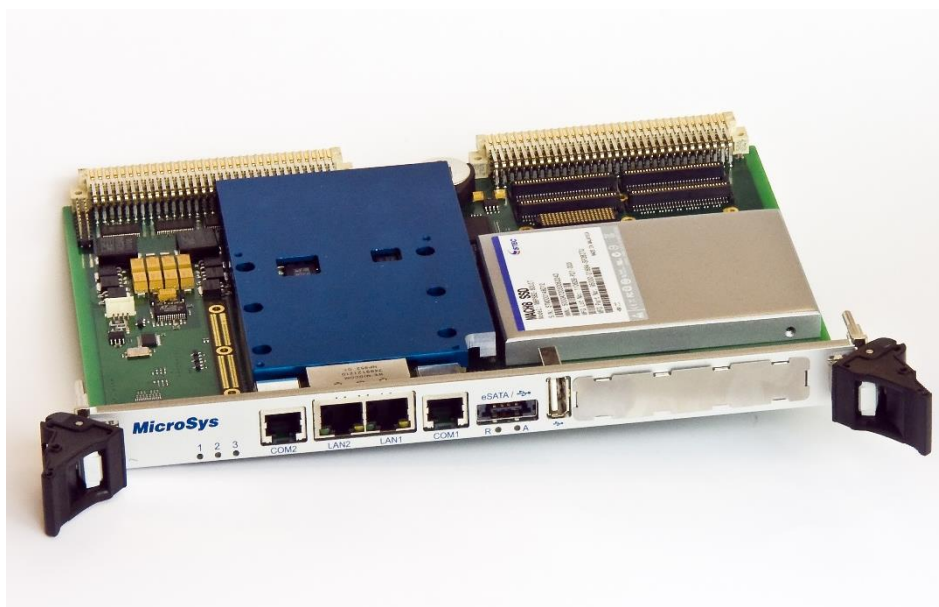

Introduction

The **miriac™** VME200 board is a member of the MicroSys 6U VMEbus board solutions, based on the Freescale QorIQ Power Architecture. The product family addresses applications from low performance and power requirements up to high performance multi core usage profiles.

The VME200 board is operated by a QorIQ P2020 dual core processor. The boards are specified for rugged and harsh environmental conditions and versions for the extended temperature range of -40°C to +85°C are available on request.

Mass storage options like an on board SATA-connector for SATA compatible 2.5" devices and a microSD-card interface are available.

Via the front panel eSATA and other I/O-functions, like 2 x USB and two GB Ethernet connectors with 1588 time stamping are easily accessible. Additional I/O functions are provided by a PMC/XMC slot and by a local bus extension, to add custom I/O like CAN, ARINC, graphics, etc...Furthermore, a temperature compensated system clock is integrated, providing a highly accurate and reliable time base.

Variants with the P1013/1022 CPUs are available to enable additional functions, like graphics or audio for a single or dual core performance envelope.

Fig. 1 Block diagram

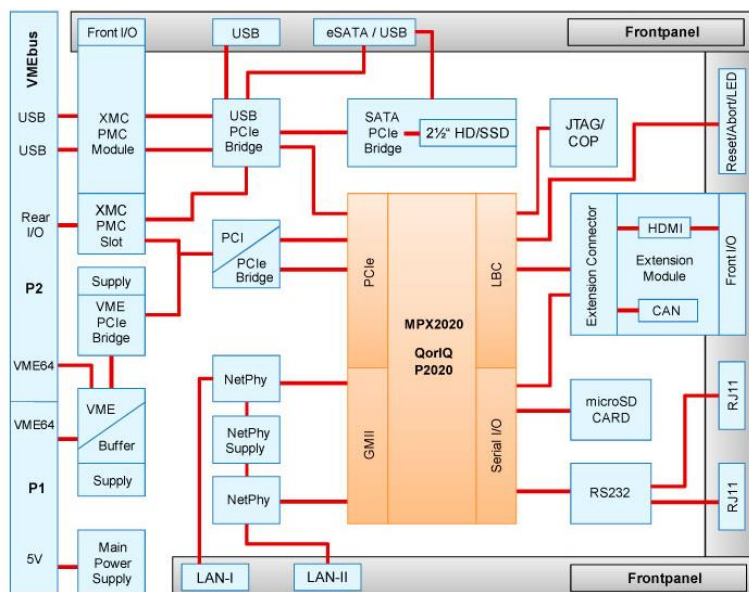

Fig. 2 Optional configurations
(with or without mountable drive)



Technical Data

General

- 6U VMEbus CPU Board, 2eSST VME-Bus interface
- conforms to VMEbus specification ANSI/IEEE STD1014-1987- and ANSI/VITA 1-1994
- QorIQ P2020 CPU, up to 1.33 GHz core speed
- up to 2 GB DDR2-soldered ECC RAM and up to 512 MB NAND Flash memory

On Board I/O

- PMC/XMC 64bit connector
- interface for memory mapped I/O modules, e.g. ARINC, graphics, other,.. via front panel
- microSD card connector
- SATA interface for standard 2,5" on board mountable mass storage devices
- 16 pin JTAG/COP interface
- CAN interface

Software Support

Linux, Microware® OS-9, VxWorks, others on request

Front Panel I/O

- 2x 10/100/1000 Mbit Ethernet
- eSATA
- 2 x USB
- 2 x RS232 RJ11
- HDMI (processor option)

Other

- various boot options
- CPU temperature monitoring
- single 5 V operation

Operating Temperature

- 0°C to +70°C
- optional -40°C to +85°C

Order #	Description	Status
839201	miriac VME200 Single Board Computer with MPX2020 SoM@1.2 GHz, 1 GB ECC RAM (DDR2), 256MB NAND Flash memory	StI
839202	miriac VME200 Single Board Computer with MPXP2020 SoM@1.2GHz, 2 GB ECC RAM (DDR2), 256MB NAND Flash memory	StI

StI: 'Stock Item' – normally available ex stock

BoO: Build on Order – will be built after order received

You are interested in a different variant?

You are very welcome to contact us!

MicroSys Electronics GmbH
Muehlweg 1
82054 Sauerlach
Germany

www.microsys.de

Phone +49 (0)8104 801-0
Hotline +49 (0)8104 801-130
Fax +49 (0)8104 801-110
Email info@microsys.de